

## SureLine® FRP Odour Control Cover

SureLine® covers are used in many waste water and sewage treatment applications the globe over.

SureLine® odour control cover systems are a lightweight custom extruded interlocking panel system that can be designed, engineered and fabricated to suit the specifics of your application. SureLine® can be designed as a load-bearing platform solution, enabling operators to safely reach covered areas. The Sureline® system can also be designed as a non-trafficable odour control cover system, meeting AS1170 requirements. SureLine® is a lighter solution to that of its heavier counterparts, Sureline® MD and HD, and is ideal for lighter smaller span tanks.

SureLine® odour control cover systems also offer a range of inspection hatches, maintenance hatches and full access hatches with safety grates installed. Covers can be manufactured in whole sections or available as an option in certain sizes to suit specific requirements. SureLine® covers may be designed to incorporate take off points and access where required.

SureLine® covers are sealed systems designed to contain odours and/or operate in conjunction with scrubber systems that draw the trapped gases off and treat them to eliminate odour, offering a 99.9% capture rate.



### Applications

Inlet Works & Grit Covers	Chlorine Contact Basins
Clarifiers	Filtrate Storage Tanks
Aeration & Equalization	Chemical Process Tanks
Sedimentation	Balance tanks
Sludge & Gravity Thickeners	

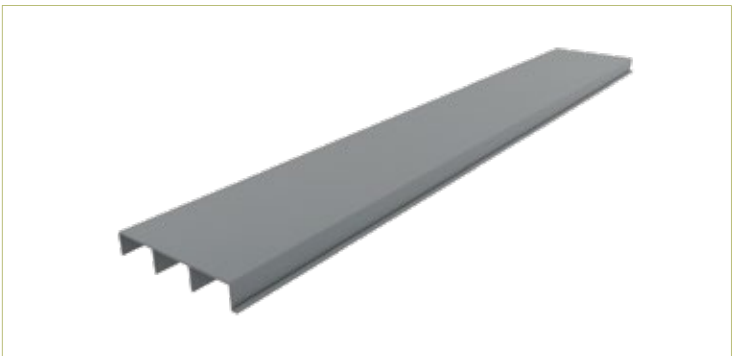

### Typical SureLine®

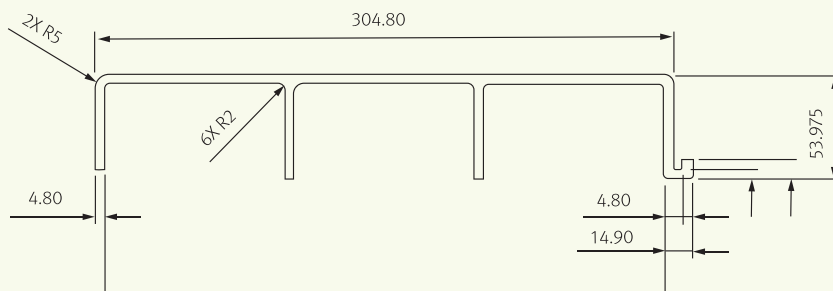

### Typical Configurations

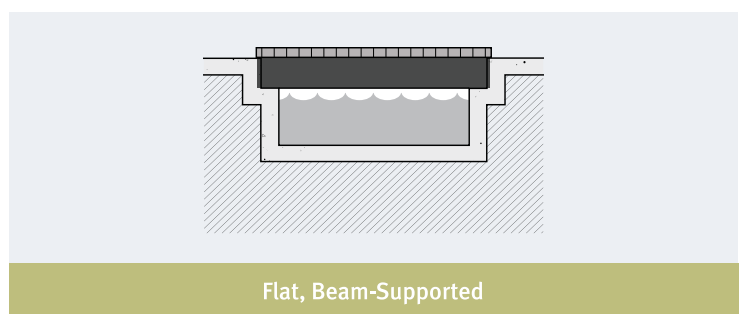
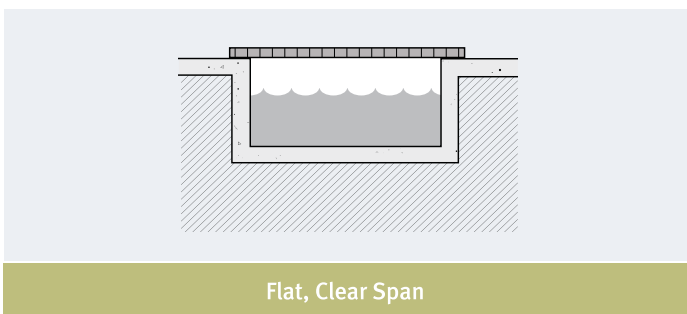

Typical Installation Details

Concrete Wall

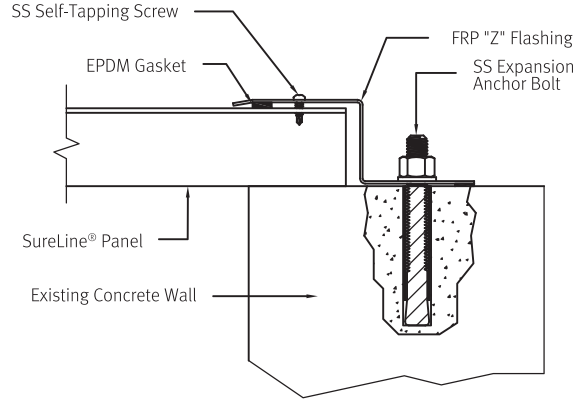

CLEAR SPAN CONNECTION

Beam Supported Connection

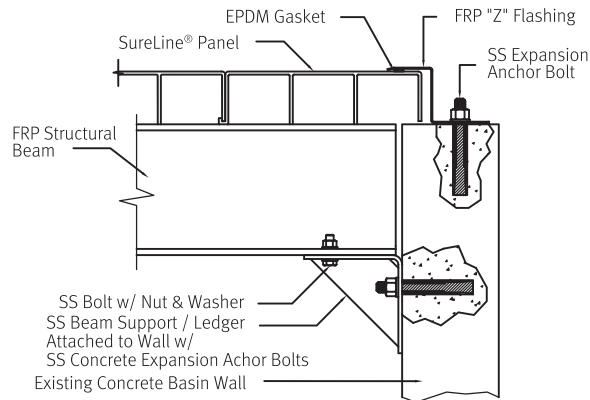

BEAM SUPPORTED CONNECTION

Typical Installation Layout

